



11kWAC Charging Post Instruction Manual(Type2)

Total solutions for the global
new energy sector



CONTENT

Preamble	01
Caveat	02
Product List	08
Technical Indicators	09
Installation Preparation	10
Process Steps	13
Fault Indicator Lamp	14
Common Troubleshooting	15



| Preamble

Welcome to the TJ series of charging posts.

In order to help you install, use and maintain the charging post correctly, please read this manual carefully.

Wherever there is a “Caution” notice in this manual, please be sure to follow it carefully to avoid injury or damage to the product. Please refer to the following for the indication of tip types and how to use them:

CAUTION: Used to supplement key information and to communicate to you safety warnings about equipment or the environment that, if not avoided, could result in equipment damage, loss of data, degradation of equipment performance, or other unpredictable consequences.

The content of this manual is for reference only and does not constitute any form of commitment, the product (including but not limited to color, size, function, etc.) please prevail in kind. If there is any inconsistency between the contents of the manual and the description on the official website, please refer to the description on the official website without prior notice.

| Safety Precautions

- Before using the operating charging post, read this manual and follow all safety precautions marked on the equipment and in the manual.
- The safety precautions in the manual do not represent all the safety matters to be observed and are only supplementary to all the safety precautions. The Company assumes no liability for any violation of the general safety operating requirements or for any violation of the safety standards for the design, manufacture and use of the equipment.
- This equipment should be used in an operating environment that complies with the provisions of this manual, otherwise it may cause equipment malfunction, and the resulting abnormal functioning of the equipment or damage to parts, personal safety accidents, and property damage are not covered by the equipment warranty.
- In addition to the standards in this manual, the use of the operating equipment should also comply with the provisions of the relevant national standards in force.
- Radio waves generated by the charging post may affect the normal operation of implanted medical devices or personal medical equipment, such as pacemakers, cochlear implants, and hearing aids. If you use any of these medical devices, consult their manufacturers for restrictions on the use of this equipment.
- Before installing or cleaning the charging post, be sure to turn off the RCBO (residual current operated circuit breaker with overcurrent protection) at the front stage of the charging post.
- Do not install the Charging Station in a strong magnetic field environment or near wireless transmitting equipment.
- Do not install or use the charger in or near flammable, explosive, chemical or vapor environments.
- Do not install or use the charging post in a location exposed to direct sunlight.
- Do not install or use the charging post in bad weather.
- When using the charging post to charge your electric vehicle, please read the relevant tips and instructions for your vehicle carefully.

| Safety Precautions

- Do not remove markings such as safety symbols, warning notices, nameplates or pipe markings on the charging post.
- Do not spray water or other liquids onto the charging post and do not submerge the charging gun in water.
- Please turn off the electric vehicle/hybrid vehicle please turn off the engine before using the charging post.
- Do not allow children to approach, touch or use the charging post.
- Do not disassemble, repair or modify the charging post by yourself.
- Do not use additional cords, adapters or adaptors.
- Do not insert fingers or sharp objects into any part of the charging post.
- Do not drop, crush or puncture the charging post as this may cause equipment failure.
- Do not fold, crush or damage any part of the charging post with sharp objects.
- Do not use the charging post if it is defective, cracked, otherwise damaged or does not work properly.
- Do not use a private generator as a power source for the charging post.
- Do not connect the charging gun to devices other than the vehicle.

Installation Precautions

Before installation, please make sure you read and follow the installation precautions carefully and prepare for the installation.

- Only professionals holding local professional qualification certificates are allowed to install and dismantle the charging post.
- Please make sure the installation operation is correct and standardized to avoid accidents such as fire or electric shock.
- Please make sure that the installation surface is sturdy and meets the load bearing requirements for installing the charging post, it is recommended that the load bearing capacity of the installation wall is $\geq 100\text{kg}$.
- Please make sure that the wall surface of the installation location is level, and reserve enough space to ensure that the charging pile is well ventilated.
- Please make sure the surface where the charging post is installed can completely cover the rear cover of the charging post.
- When installing the wiring, be sure to install the protective earth wire first; when removing the equipment, be sure to remove the protective earth wire last.
- Do not install or remove the power cord with electricity.
- Make sure that the charging cable is properly connected before turning on the front stage RCBO.
- After connecting the front stage RCBO, do not touch the terminals on the back cover directly or with other conductors.
- Use a cable that meets local code requirements and make sure the cable insulation is intact.
- When installing the equipment, use a screwdriver with the appropriate range to tighten the screws. When tightening with a screwdriver, make sure that the screwdriver is not tilted.

Installation Precautions

- During the power cable placement, looped and twisted phenomena are strictly prohibited.
- The distance between the cable and the periphery of the heat generating device or heat source area is at least 30mm.
- If the length of the power cable is found to be insufficient, the power cable must be replaced again, and it is strictly prohibited to make joints or welding points in the power cable.
- After installation, be sure to seal the unrouted power cord routing holes with adhesive plugs to ensure a good charging seal.
- Installation location without strong vibration and shock, no strong electromagnetic interference (such as car wash, welding machine, arc furnace and other serious interference with the power grid near the environment).
- The I²T value at the EV socket of the charging station should not exceed 75000A²s if under short circuit condition.

Use Of Charging Posts

Please read the safety precautions carefully before using the charging post.

- Please make sure that the charging post is used without cracks, damages and other abnormalities.
- Please make sure that there is no liquid or other foreign matter in the head of the charging gun or inside the charging port of the vehicle.
- The charging post is a plug-and-play charging method, and charging can be stopped by the emergency stop button on the side of the vehicle.
- Do not unplug the charging gun during the charging process.
- Charging stops automatically when the battery is fully charged.
- Get detailed instructions in the "Common Troubleshooting" section.

Stop Charging

Please stop charging via the vehicle-side stop/button.

Swipe Card Charging

- 1, Remove the charging gun, insert the charging gun into the socket at the end of the vehicle and make sure it is fully inserted.
- 2, Place the RFID card on the RFID card swipe area of the stake to charge. The blue light flashes to indicate successful card swiping.

Routine Maintenance

- No special maintenance is required for the charging post. It is recommended that the post housing and accessories be inspected and cleaned every 6 months.
- Please check the appearance of the charging post and cable for any damage.
- Please use a rag to clean the surface of the charging post, do not spray water directly onto the charging post.
- Do not use corrosive chemical cleaners, glass cleaners or organic solvents to clean the charging post.

| Other

Transportation/Storage

- The Charging Post should always be transported in its original packaging and care should be taken not to place other items on top of the Charging Post.
- The Charging Post shall be stored in a clean, dry, well-ventilated area free from corrosive influences and where the relative humidity does not exceed 80%.
- Transportation and storage conditions must not exceed the limits of the technical specifications.

Dismantle

- This equipment is only allowed to be disassembled by professionals who hold local professional qualification certificates.
- Before dismantling, please turn off the front stage power of the charging post, then refer to the installation procedure and dismantle the charging post in the reverse order.

Disposal/Scrapping

- Please observe local laws and regulations for proper and environmentally friendly disposal of charging posts, and drop them off at designated collection points for used and end-of-life electronic equipment.
- Please be careful not to dispose of electronic equipment as normal household waste.

Troubleshooting And Handling

- Please refer to the “Common Troubleshooting” section in this manual for detailed instructions on troubleshooting and handling.



Production Machine*1



Socket*1



4*24 Countersunk Head Screw*3



3*40 Countersunk Head Screw*6



Small Yellow Croaker*9



Instruction Manual*1

Shenzhen Good Electronic Technology Co., Ltd.
Product shipment inspection report

Class	Subject Type	Inspection Date	Date of inspection
Product Model	Order No.	Batch No.	Inspection Status
Inspection Date	Inspector	Inspector	Inspector
Inspection Items			
1. Check the appearance of the product, including the color, texture, and size, and ensure that it meets the requirements.			OK
2. Check the function of the product, including the power, speed, and other parameters, and ensure that it meets the requirements.			OK
3. Check the safety of the product, including the electrical safety, mechanical safety, and other aspects, and ensure that it meets the requirements.			OK
4. Check the packaging of the product, including the quantity, quality, and other aspects, and ensure that it meets the requirements.			OK
5. Check the documents of the product, including the certificate of origin, the certificate of conformity, and other documents, and ensure that they are complete and correct.			OK
6. Check the storage and transportation of the product, including the storage conditions, the transportation method, and other aspects, and ensure that they meet the requirements.			OK
7. Check the return and after-sales service of the product, including the return policy, the after-sales service, and other aspects, and ensure that they meet the requirements.			OK
8. Check the overall quality of the product, including the production process, the quality control, and other aspects, and ensure that they meet the requirements.			OK
9. Check the compliance of the product with the relevant standards and regulations, including the CE mark, the RoHS mark, and other marks, and ensure that they are valid and correct.			OK
10. Check the overall satisfaction of the customer, including the customer's feedback, the customer's complaint, and other aspects, and ensure that they are handled and resolved.			OK

Shenzhen Good Electronic Technology Co., Ltd.
Shenzhen, China

Shipment Inspection Report*1



IC Card*2

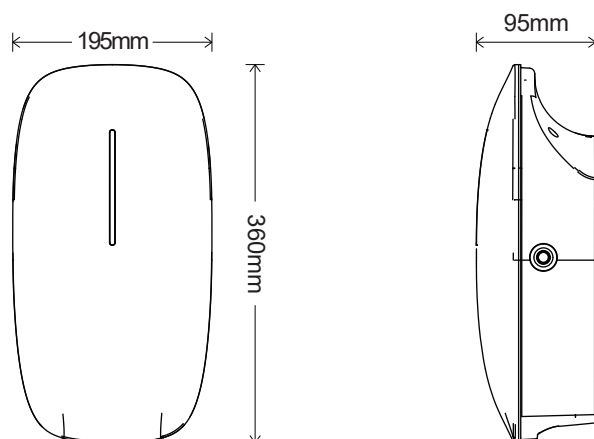

Operating Voltage Range	400Vac±15% (Three phase)
Supported Grid Types	Three phase, five-wire; TN, TT, IT
Rated Power Output (Current)	Three phase: 11kW (16A)
Product Weight	3.15 kg
Working Environment Temperature	-25°C ~ +50°C
Supply Frequency	50/60Hz
Product Size	360*195*95 mm
Transportation/storage Temperature	-40°C ~ +60°C
Relative Humidity	5%RH ~ 95%RH(Condensationless)
Altitude	0m ~ 2000m
Communication Method	WiFi 2.4GHz/ BLE 5.0 / FE 100Mbps
Activation Method	RFID, App
Protection Level	IP65
Fulfillment Criteria	EN 61851-12019, IEC62196-2

Preparation for installation

Please confirm the following information before installation:

- The electrical load balance of the house is able to meet the use of the charging pile.
- The air-open outlet has been prepared to meet the installation scenario and usage requirements.
 - When the AC input cable alignment is exposed outdoors for 3m and above, please consult the local installer, and it is recommended to configure a lightning protector before the charging pile front-stage RCBO, with specifications meeting:
 - $U_c=385V$ AC, $I_n \geq 10kA$, $U_p \leq 2kV$; at least 3m cable length is required between the lightning protector and the charging pile.
 - If the charging pile is connected by wired connection, a long enough network cable is ready.
 - If the charging pile is connected by WiFi, make sure the installation area is covered by wireless network.

Prepare tools and accessories

- Protective tools: safety helmet, protective gloves, insulated shoes.
- Hardware installation tools: Phillips insulated torque screwdriver (M4/M5/M6), impact drill and drill bit, marking pen.
- Measuring instruments: steel tape measure, leveling ruler

Installation process

1、 Fixed wall fittings

- Please install the charging post on the wall with load-bearing capacity $\geq 100\text{kg}$, please do not punch holes directly through the back cover, otherwise it will easily cause damage to the back cover.
- Place the wall-mounted accessories and the lance holder on the wall, keep the horizontal position, and mark the hole-punching position with a marking.
- Use an impact drill to make holes in the marked locations and place expansion tubes.
- Use wall screws to fix the rear wall mounting accessories and gun mount to the wall. And hang and fasten the charging post on the wall mounting accessory and place the charging gun on the gun mount.
- Use countersunk head self-tapping Phillips screws (M4*40)*8 to lock the screw holes under the charging stake.

2、 Connecting the power cord

- Please make sure the crimp frame is loosened to the bottom, connect the wire to the corresponding terminal, and tighten the screw in clockwise direction. Make sure that the cable is securely mounted, and finally check if the screws are in normal condition.

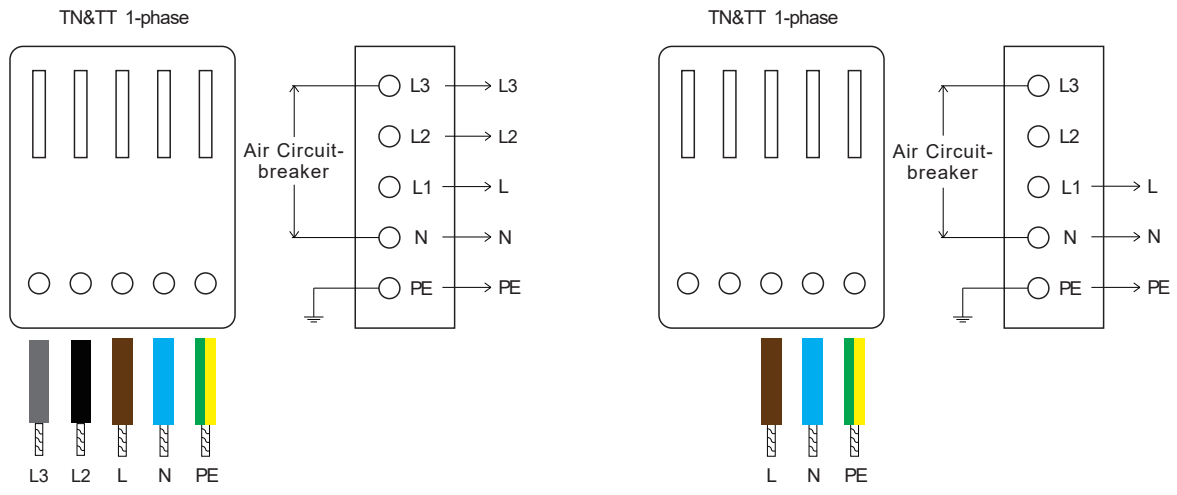
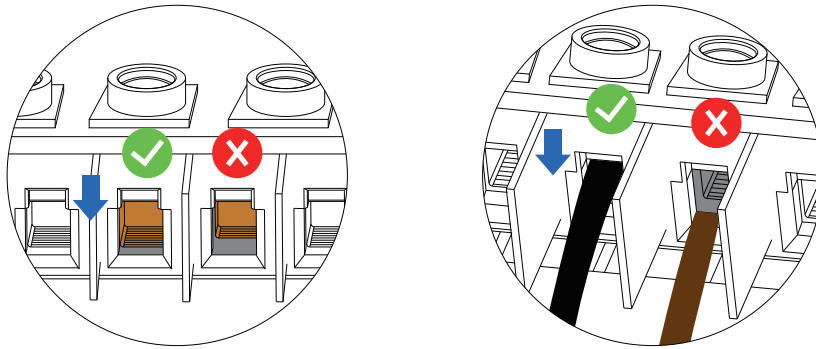

Note: Pay attention to the wire marking when wiring, and the ground wire must not go over the air switch.

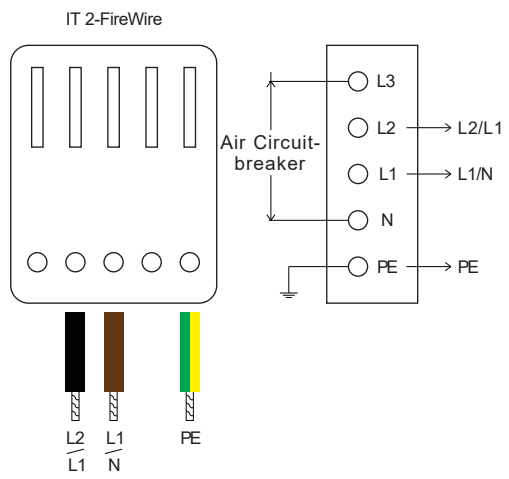

Note: The electrical load of the house meets the demand of the charging pile, and the charging pile air-open forward wire needs to be 25mm^2

IC Card*2



Pragmatic
Indicator light:
green always on



Insert A Gun
Indicator light:
green flashing



Charge Waiting
Indicator light:
blue always on



Charging
Indicator light:
blue flashing



Charging Complete
Indicator light:
blue always on



Faults
Indicator light:
red flashing

Working State	Indicator Light Status			Code
	Red	Green	Blue	
Idle	/	Flash	/	/
Idle	/	Always On	/	/
Insert A Gun	/	Flash	/	/
Charging	/	/	Flash	/
Charging Complete	/	/	Always On	/
Overvoltage Protection	Flash 1Time	/	/	E01
Undervoltage Protection	Flash 2 Time	/	/	E02
Overcurrent Protection	Flash 3 Time	/	/	E03
PCB Motherboard Over-temperature Protection	Flash 4 Time	/	/	E04
Grounding	Flash 5 Time	/	/	E05
CP Voltage Protection	Flash 6 Time	/	/	E06
Relay Failure	Flash 7 Time	/	/	E07
Leakage Protection	Flash 8 Time	/	/	E08
E-stop Button	Flash 15Time	/	/	E15
Card Reader Failure	Flash 16 Time	/	/	E16
Malfunction Of Electric Meter	Flash 17 Time	/	/	E17
Swipe Stop	/	/	/	S1
APP Stop	/	/	/	S2
Fully Charged Stop	/	/	/	S3
Cart Stop	/	/	/	S4
Insufficient Balance Cessation (Operational Version)	/	/	/	S5
Charge Interruption (Operational Version)	/	/	/	S6

Fault Name	Possible Causes Of Malfunctions	Exclusion Suggestions
Indicator light does not come on	Abnormal front-end input power supply	Troubleshoot the front end input power lines.
	Abnormal AC cable (broken, loose, etc.)	Line up the cables.
	Anomalies within the charging pile	Contact Technical Support.
Red Light Flash 1 Time	Input voltage above 265V	Check that the input voltage is in the normal range.
Red Light Flash 2 Time	Input voltage below 85V	Check that the input voltage is in the normal range.
Red Light Flash 3 Time	Output current exceeds set upper limit	Reduce the vehicle charging current, or adjust the charging post current.
Red Light Flash 4 Time	PCB motherboard over-temperature protection	Stop charging, or reduce the power.
Red Light Flash 5 Time	Grounding	Check that the outlet is grounded.
Red Light Flash 6 Time	CP Voltage Protection	Cannot be recovered after reboot, contact technical support.
Red Light Flash 7 Time	Relay Failure	Cannot be recovered after reboot, contact technical support.
Red Light Flash 8 Time	Leakage Protection	Danger of current leakage exists, disconnect the front-stage circuit breaker and reapply power after 5 seconds.
Red Light Flash 15 Time	E-stop Button Malfunction	Cannot be recovered after reboot, contact technical support.

Fault Name	Possible Causes Of Malfunctions	Exclusion Suggestions
Red Light Flash 16 Time	Card reader malfunction	Cannot be recovered after reboot, contact technical support.
Red Light Flash 17 Time	Malfunction of electric meter	Cannot be recovered after reboot, contact technical support.
Indicator light is normal and not charging	Charging gun not plugged in, not successfully connected to the car	Try re-plugging the charging gun.
	Foreign object in the charging gun connector	Check the charging gun connector and remove any foreign objects if found.
	Foreign object in the charging gun connector	Contact Technical Support.
APP Connection Failure	WIFI Occupied	Double-click the button three times and reconnect.